



# AF10 PWM Generator



## Manual

Valid as of firmware version v1.5.0



---

# AF10 PWM Generator

---

## *Manual*

### **Contents**

1	Controls .....	4
1.1	Main switch (back) .....	4
1.2	ON button .....	4
1.3	Esc button .....	4
1.4	Setup button .....	4
1.5	View button .....	4
1.6	OK button .....	4
1.7	Output On button .....	4
1.8	Frequency rotary encoder .....	4
1.9	Duty rotary encoder .....	4
2	Connections .....	5
2.1	OUT – main output of the PWM generator .....	5
2.2	TTL – TTL output of the PWM generator .....	5
2.3	USB .....	5
2.4	Extension .....	5
2.5	AUX (back) – 15-pin sub D socket .....	6
2.6	RS232 (Rear panel, optional) .....	6
3	Operation .....	7
3.1	Main screens .....	7
3.1.1	Main screen .....	7
3.1.2	File explorer (only Automation and Engineering versions) .....	7
3.1.3	Ramp screen .....	8
3.2	Setup menu .....	9
3.2.1	Output voltage .....	9
3.2.2	Output configuration .....	9
3.2.3	Polarity .....	9
3.2.4	TTL output voltage .....	9
3.2.5	Inputs (Automation version and above) .....	9
3.2.6	Remote input (Automation version and above) .....	9



3.2.7	Extension mode (only Engineering version) .....	11
3.2.8	Ext. PushPull dead time (only Engineering version) .....	11
3.2.9	Ext. Full Bridge dead time (only Engineering version).....	11
3.2.10	Extension Delay EF (only Engineering version).....	12
3.2.11	Lock (Automation version and above) .....	12
3.2.12	Restore output (Automation version and above) .....	12
3.2.13	PWM steps.....	12
3.2.14	Contrast .....	12
3.2.15	Activation code.....	12
3.2.16	Language.....	12
4	Characteristics of the <i>OUT</i> connector .....	13
4.1	Output current .....	13
4.2	Voltage in open drain mode .....	13
4.3	Current sink capability.....	13
5	Technical data.....	14

## 1 Controls

### 1.1 Main switch (back)

The main switch disconnects the unit completely from the mains.

### 1.2 ON button

The unit can be switched on and off easily with the ON button.

### 1.3 Esc button

Most operating functions can be cancelled with the Esc button.

### 1.4 Setup button

By pressing the button the Setup menu is displayed.

### 1.5 View button

By pressing the button the system changes between the different screens (main screen, scope, file explorer, ramp screen).

### 1.6 OK button

This button acknowledges the different settings.

### 1.7 Output On button

This button switches the *OUT* and *TTL* outputs on and off.

### 1.8 Frequency rotary encoder

- Setting of the PWM frequency

*Note:*

In Forward Converter mode the frequency is adjustable only if the output is off.

- Holding down and turning:

By holding down and simultaneous turning of the encoder the amplitude of the PWM signal at the *OUT* connector (3..24 V) can be set.

- Selection of the input configuration in the *Inputs* setup menu

### 1.9 Duty rotary encoder

- Setting of the duty cycle
- Different selection functions, depending on the main screen/setup menu
- Pressing refers in most cases to the OK button.

## 2 Connections

### 2.1 *OUT* - main output of the PWM generator

The PWM signal is supplied between *OUT* and *GND* with the set frequency, duty cycle and output voltage.

### 2.2 *TTL* - TTL output of the PWM generator

The set PWM signal is supplied with TTL levels (3.3 V/5 V, depending on the setting in the Setup menu) between *TTL* and *GND*.

### 2.3 *USB*

Connector for FAT/FAT32-formatted USB sticks to transfer ramp traces (*Automation* and *Engineering* versions)

### 2.4 *Extension*

Connector for external power modules (*Engineering* version)

Pin no.	Function
1	GND
2	OUT A (HighSide half bridge 1)
3	OUT B (LowSide half bridge 1)
4	OUT C (HighSide half bridge 2)
5	OUT D (LowSide half bridge 2)
6	OUT E (active rectifier 1)
7	OUT F (active rectifier 2)
8	GND
9	Analogue In (0..5 V)
10	12 V output, 50 mA max.



## 2.5 AUX (back) – 15-pin sub D socket

Various galvanically isolated connectors for remote control of the PWM generator

Pin no.	Function
1	Switching input 1 low active
2	Switching input 2 low active
3	Switching input 3 low active
4	Switching input 4 low active
5	Switching input 5 low active
6	Switching input 6 low active
7	Analogue input: 0..5 V/0..10 for external setting of the duty cycle
8	Analogue output: 0..5 V = 0..100% duty cycle
9	Switching input start/stop (ramp), low active
10	GND
11	GND
12	GND
13	GND
14	GND
15	PWM output 5 V

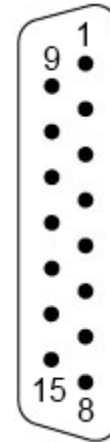

The switching inputs and the start/stop input are low active optically coupled inputs. Voltages up to 30 V are permitted for these inputs.

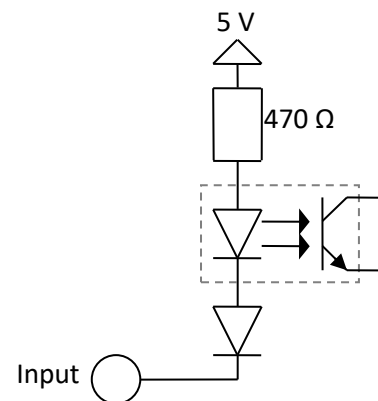

## 2.6 RS232 (Rear panel, optional)

If the optional galvanic isolated RS232-module is fitted, there is a female SUB-D-plug on the rear panel of the AF10 with standard RS232-pinning.

Pin no.	Function
2	TXD
3	RXD
5	GND

## 3 Operation

### 3.1 Main screens

By pressing the *View* button the system changes between the following screens:

#### 3.1.1 Main screen

Frequency, duty cycle, output voltage and status information are displayed on the main screen.

The frequency and duty cycle can be set using the appropriate rotary encoders.

##### 3.1.1.1 Scope screen

This screen displays the PWM signal currently measured at the *OUT* connector.

The frequency and duty cycle can be set using the appropriate rotary encoders.

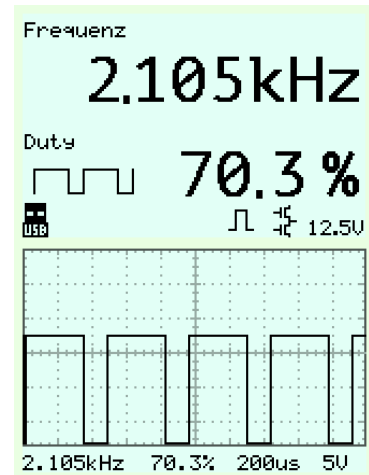

#### 3.1.2 File explorer (only Automation and Engineering versions)

If a USB stick is inserted all the CSV files found are displayed. By selection with the *Duty* rotary encoder and acknowledgement with *OK*, the ramp saved in the CSV file is loaded and the screen changes to the ramp screen.

The USB stick can then be removed. The loaded ramp is also available after the unit is restarted.

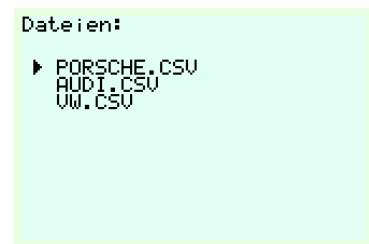

##### 3.1.2.1 Format of the CSV file:

###### First line:

Description, shown in the display.

###### Further lines:

Arbitrary content – is ignored.

###### “Points” line

If the first column of a line contains the text “Points”, this indicates for the unit that the table with the ramp values begins in the following line.

	A	B	C	D
1	Preis Ing. Endurance Test			
2	Endurance Test Summer 2017			
3	Test @ Overload			
4	Time[s]	Duty[%]	Frequency[Hz]	Voltage[V]
5	Points			
6	0	70,0	100	3,0
7	20	25,5	100	10,5
8	22	0,0	100	10,5
9	25	70,0	200	4,2
10	25	20,0	100	4,0

###### Column A – Time

The absolute time in seconds is entered in column A. Numbers with up to three decimal places are permitted. The time resolution is 1 ms.

The maximum possible time is 999,999 s.

If the AF10 is to generate a hard step in duty cycle, frequency or voltage, the same time must be entered in two successive lines with different set points.

### Column B – Duty cycle

The associated duty cycle is entered in column B. Decimal numbers are permissible, but only the first decimal place is evaluated.

If the AF10 generator is operated in the *H-bridge/H-bridge single-side* extension modes, negative values can also be entered here.

### Column C – Frequency

The associated frequency in Hertz can be entered in column C. Valid values are between 0.1 Hz and 1,000,000 Hz.

This column is optional. If it is left empty, the frequency currently set at the unit is used.

### Column D – Voltage

The associated voltage/amplitude in volts can be entered in column D.

Valid values are from 3.0 V to 24.0 V.

The voltage change speed is limited to approx. 500 mV/ms by the hardware.

This column is optional. If it is left empty, the voltage currently set at the unit is used.

Up to 1,000 data points/table lines are permissible.

The file must be saved in CSV format and must look like the image on the right when opened in a normal editor. The columns must be separated by semicolons (standard with German Excel versions).

Excel ends some lines with a semicolon. This is permitted and does not cause any problems.

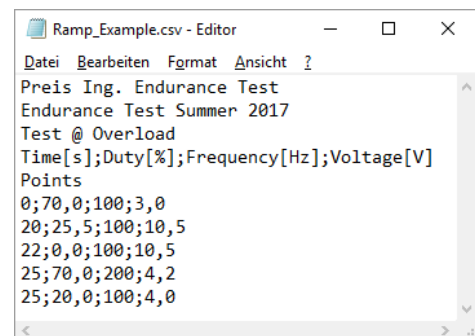

```
Ramp_Example.csv - Editor
Datei Bearbeiten Format Ansicht ?
Preis Ing. Endurance Test
Endurance Test Summer 2017
Test @ Overload
Time[s];Duty[%];Frequency[Hz];Voltage[V]
Points
0;70,0;100;3,0
20;25,5;100;10,5
22;0,0;100;10,5
25;70,0;200;4,2
25;20,0;100;4,0
```

### 3.1.3 Ramp screen

Status screen of the ramp function

OK button: start/pause of ramp

ESC button: stop

The ramp can also be activated by using the start/stop switching input.

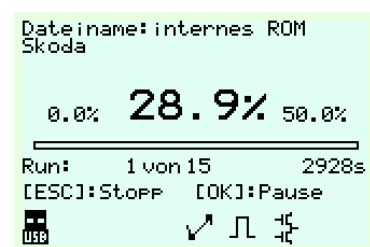



## 3.2 Setup menu

**Selection of the setup point:** turn the *Duty* rotary encoder

**Changing the setup point:** press *OK* – turn the *Duty* rotary encoder

### 3.2.1 Output voltage

Amplitude of the PWM signal at the *OUT* connector (3..24 V)

**Note:** this value can also be adjusted outside the Setup menu by holding down and turning the *Frequency* rotary encoder.

### 3.2.2 Output configuration

Selection between PushPull and open drain configuration

### 3.2.3 Polarity

Selection whether or not the PWM output should be inverted.

### 3.2.4 TTL output voltage

Amplitude at the *TTL* output

### 3.2.5 Inputs (Automation version and above)

Configuration of the external switching inputs

- Selection of switching input configuration: *Frequency* rotary encoder
- Setting of the associated duty cycle: *Duty* rotary encoder

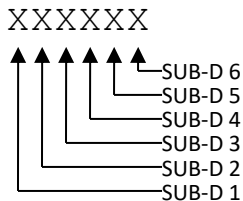

### 3.2.6 Remote input (Automation version and above)

The Duty cycle can be set by remote input sources, depending on version and configuration.

1. 0..5V through analogue input pin on 15pin SUB-D-connector
2. 0..10V through analogue input pin on 15pin SUB-D-connector
3. 0..5V through analogue input pin on *Extension*-connector
4. RS232, if RS232-extension is fitted

#### 3.2.6.1 Analogue

The duty cycle is adjustable from 0 to 100% within the selected voltage range. In operating modes with negative duty cycles, the polarity can be inverted by using the digital input pin 6.

### 3.2.6.2 RS232

If an RS232-module is fitted, the AF10 is remote controllable by RS232.

Baud rate : 115200 Bd  
Stop-bits : 1  
no parity, no flow control

#### Commands

A control command consists of a prefix, the set value and a linefeed/carriage return (10 or 13 or both). For ON/OFF there is no value.

ON - Set output on  
OFF - Set output off

#### Prefixes:

D - Duty-Cycle  
F - Frequency  
V - Output voltage

The prefix is followed by the set value and a linefeed/carriage return.

At higher frequencies the frequency and duty cycle are rounded to the next settable value.

#### Examples:

D55	Set duty cycle to 55 %
D33,3	Set duty cycle to 33.3 %
D-57.7	Set duty cycle to -57.7 %
F50.5	Set frequency to 50.5 Hz
F1000000	Set frequency to 1 MHz
V14.3	Set output voltage to 14.3 V

The incoming commands are executed once per millisecond and are present on the output 2-3ms later. If more than one command with same prefix is received within one millisecond, the first one may be ignored. At low frequencies < 1kHz a large update delay of frequency or duty cycle may occur.

#### TXD

Every 3 ms the AF10 sends the current values in a CSV compatible format.

#### Example:

73.2; 434108.5; 13.2; ON

Duty cycle : 73,2 %  
Frequency : 434108,5 Hz  
Voltage : 13,2 V  
Output : On

### 3.2.7 Extension mode (only Engineering version)

Different external power modules can be connected at the *Extension* connector at the front of the unit.

If an Extension mode is activated, the *OUT* and *TTL* outputs are deactivated.

Selection is possible between:

- LowSide Out:  
Only output B of the connector is active.
- HighSide Out:  
Only output A of the connector is active.
- PushPull:  
Outputs A and B are active. The signals are inverted to each other.  
The dead time can be set in the Dead Time setup menu.
- Forward converter:  
Complete control of a phase-shifted forward converter including active rectifiers.  
Outputs A and B control one half bridge, C and D the second.  
Outputs E and F control the active rectifiers.
- H-bridge:  
Both half bridges of an H-bridge are controlled in such a way that both are clocked with 50% at 0% PWM setting. The bridge voltage is then 0 V. The PWM value can vary between –100% and +100% in this mode.  
If controlled by analogue input, the polarity of the duty cycle can be controlled via the digital input pin 6.  
Outputs A and B control one half bridge, C and D the second.
- H-bridge, single-side:  
Only one half bridge is clocked. The second is controlled with a static signal. By selecting inverted/non-inverted PWM it can be determined whether the LowSide FET (non-inverted) or the HighSide FET (inverted) is activated. The PWM value can vary between -100% and +100% in this mode. With negative values the second half bridge is clocked and the first is controlled with a static signal.  
If controlled by analogue input, the polarity of the duty cycle can be controlled via the digital input pin 6.
- Outputs A and B control one half bridge, C and D the second.

### 3.2.8 Ext. PushPull dead time (only Engineering version)

Setting of the dead time between external HighSide and LowSide MOSFET from 0 to 6,000 ns.

**CAUTION:** too low dead times can result in defects at external power modules.

### 3.2.9 Ext. Full Bridge dead time (only Engineering version)

Setting of the dead time between HighSide and LowSide MOSFETs of the external full bridge from 0 to 6,000 ns.

**CAUTION:** too low dead times can result in defects at external power modules.

### 3.2.10 Extension Delay EF (only Engineering version)

Delays the switching off of each active rectifier by the set time (0..2,000 ns).

### 3.2.11 Lock (Automation version and above)

By activating this setting, all controls of the PWM generator which have a direct influence on the output signal are locked.

### 3.2.12 Restore output (Automation version and above)

**Off:** all outputs are off after the unit is switched on.

**On:** after (re)start the PWM generator starts (e.g. after an interruption in power supply) in the last known configuration and activates the output again immediately, performs a ramp, etc.

### 3.2.13 PWM steps

Sets the behaviour of the *Duty* rotary encoder.

### 3.2.14 Contrast

Sets the display contrast.

### 3.2.15 Activation code

By entering an activation code to be purchased separately the unit can be updated to a version with a wider range of functions.

The right-hand digits are set with the *Duty* rotary encoder, the left-hand digits with *Frequency*.

### 3.2.16 Language

Selects the menu language.

## 4 Characteristics of the *OUT* connector

### 4.1 Output current

The PWM generator can deliver output currents of  $\pm 1$  A. At higher currents the output is deactivated and the error message “*Overcurrent*” is displayed.

In open drain mode the PWM generator can switch up to 1 A to ground. At higher currents the output is deactivated and the error message “*Overcurrent*” is displayed.

#### **Caution with capacitive loads:**

With high PWM frequencies, even a capacitive load of only 20 nF can result in a high alternating current above  $2 A_{RMS}$ , which is not identified by the overcurrent shutdown, as the current mean value remains at almost 0 A.

In this case an internal fuse is tripped, which can be exchanged by the manufacturer.

### 4.2 Voltage in open drain mode

In open drain mode, voltages up to 30 V at the *OUT* connector are permitted.

At voltages above 36 V the output is clamped, which can result in defects to the PWM generator.

The unit has **no** internal freewheeling diode.

### 4.3 Current sink capability

The PWM generator can absorb a limited amount of energy in PushPull operation, resulting in warming of an internal high-power zener diode. If a critical temperature is exceeded, the output of the PWM generator is deactivated and the error message “*Overvoltage*” is displayed.

Current sink occurs for example if a connected electric motor is slowed down due to the duty cycle being used. Current then flows into the PWM generator.

Short-term feedback currents up to 1 A are permitted. Higher currents result in the output being deactivated.

Active current sink is displayed by a flashing Zener diode.

## 5 Technical data

Power supply	100..250 V AC 50/60 Hz, 130..350 V DC
Mains fuse	1.6 A, slow blow
Unit type	Protection class 1
Ambient temperature	0° C..40° C, non-condensing
Frequencies	0.1 Hz..1 MHz @ 3..12 V 0.1 Hz..500 kHz @ 3..24 V 0.1 Hz..100 kHz with PWM distributor
Frequency resolution	0.1 Hz 5.95 ns period steps at high frequencies 11.9 ns period steps in full bridge mode
Frequency accuracy	< 100 ppm
Duty cycle	0..100%
Duty cycle resolution	0.1% 5.95 ns at high frequencies 11.9 ns in full bridge mode
Accuracy	OUT connector
Duty cycle	TTL connector
	Extension connector
	PLC connector
	50 ns
	20 ns
	20 ns
	100 ns
<b>OUT connector</b>	
Output voltage	3..24 V ± 5%
Output current	1 A max.
Input current	1 A max.
Output impedance	< 250 mΩ
<b>TTL connector</b>	
Output voltage TTL	3.3 V/5 V ± 5%
Output impedance	typ. 250 Ω
<b>AUX connector</b>	
Galvanic isolation	> 100 V
AUX <-> Front outputs & Extension socket	
Max. input voltage at switching inputs	30 V
Low level input voltage at switching input	< 1 V
High level input voltage at switching input	> 4 V
Max. input voltage Analogue In	11 V
Input impedance Analogue In	typ. 100 kΩ
Output impedance PWM Out	typ. 1 kΩ
Output impedance Analogue Out	typ. 1 kΩ
<b>PWM distributor extension (open drain)</b>	
RDSon <sub>max</sub>	6 Ω @ 50 mA
I <sub>max</sub>	200 mA (protected with 290 mA polyfuse)
U <sub>max</sub>	27 V